

## Isolated 2SW 1Leg 2A Smart Gate Drive Module

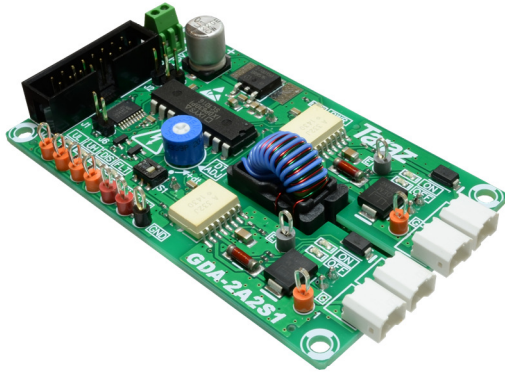

### Applications

- 2 Switch Isolated IGBT/MOSFET Gate Drive
- DC-DC Converters
- Switched Mode Power Supplies
- Single/ Dual Phase PFC Rectifiers

### Compliance

- ROHS

### Features

- Best Cost to Performance Ratio in the Market.
- Suitable for 1200V IGBTs and Power MOSFETs up-to 120A.
- 2A Peak Gate Drive Current.
- 3000 V<sub>RMS</sub> Input to Output Isolation.
- Short-Circuit Protection Through Desaturation Detection.
- Active Miller Clamp.
- Output UVLO Protection.
- Output Clamping Protection.
- Isolated Fault Feedback.
- Soft IGBT Turnoff in Case of Fault.
- Configurable Fault Latch Shutdown.
- Configurable PWM/Dual Inputs.
- Configurable Dead-Time.
- 50KV/us Minimum Common Mode Rejection (CMR).
- Very Low Propagation Delay of 250ns (Maximum) for High Frequency Operation.
- Input & Output Indication LEDs for Visual Feedback.
- Input & Output Test points for easy testing.
- Built-in 5V Regulator for Powering up External Control Circuitry.

### Description

The GDA-2A2S1 is high performance fully isolated dual IGBT/MOSFET gate drive module. It is specially designed for fastest prototyping of DC/DC Converters, active rectifiers and Inverters in research and educational environments. The drive uses Avago ACPL-332J smart and high performance gate driver IC, and features dead time generation logic, fault latch logic, input and output indication LEDs, test points and built in 5V regulator which could be used to power up the external control circuitry.

But the most notable feature of this module is that it detects short circuit condition using desaturation detection and can safely turn off the switch and give the controller an isolated fault feedback signal. The user can also enable fault latch circuitry which automatically shuts down the module and does not resume operation till complete power reset.

This product can be ordered with different input and output connectors, making it suitable as a plugin module, PCB mounted module or free hanging module.

### Revision History Table

Version	Release Date	Changes
1.0	16/08/2015	First Version Released

### WARNING AND DISCLAIMER !

ATTENTION PLEASE! THE INFORMATION HEREIN IS GIVEN TO DESCRIBE CERTAIN COMPONENTS AND SHALL NOT BE CONSIDERED AS A GUARANTEE OF CHARACTERISTICS. TERMS OF DELIVERY AND RIGHTS TO TECHNICAL CHANGE RESERVED. WE HEREBY DISCLAIM ANY AND ALL WARRANTIES, INCLUDING BUT NOT LIMITED TO WARRANTIES OF NON-INFRINGEMENT, REGARDING CIRCUITS, DESCRIPTIONS AND CHARTS STATED HEREIN. CUSTOMER IS SOLELY RESPONSIBLE OF PROPER AND LEGAL USE OF ALL PRODUCTS OFFERED BY TARAZ TECHNOLOGIES.

### SAFETY NOTICE !

ATTENTION PLEASE! THIS DEVICE IS ESD SENSITIVE AND NEEDS TO BE HANDLED WITH CARE. HIGH VOLTAGE CONDITION MAY OCCUR DURING OPERATION OF THE DEVICE, AND HENCE USER IS SOLELY RESPONSIBLE OF EQUIPMENT AND PERSONNEL SAFETY. TARAZ TECHNOLOGIES SHALL NOT BE HOLD LIABLE FOR ANY DAMAGE TO PERSONNEL AND/OR PROPERTIES AS A RESULT OF USING THIS DEVICE. USER MUST TAKE ADEQUATE STEPS TO ENSURE ELECTRICAL AND MECHANICAL SAFETLY OF THE DEVICE IN USE.

### Table of Contents

---

Features .....	1
Applications .....	1
Description .....	1
Compliance .....	1
Revision History Table.....	2
WARNING AND DISCLAIMER ! .....	2
SAFETY NOTICE ! .....	2
Table of Contents .....	3
Ratings & Characteristics .....	4
Ratings & Characteristics (Continued).....	5
Block Diagram .....	6
Pin Description .....	7
Application Information.....	8
Typical Application Circuit .....	8
Operational Requirements.....	8
Power Supply & Configuration (J2, J3& J4).....	8
Output Connection (J7-J10).....	8
Fault Latch Disable (J6) .....	8
Application Information (Continued).....	9
Operation Modes (S1) .....	9
Configurable Dead Time (DT ADJ) in PWM Mode.....	9
Input & Output Indication LEDs, Test Points.....	9
Mounting and Safety.....	9
Mechanical Drawing .....	10
Ordering Information .....	11

## Ratings & Characteristics

\*All ratings are given at  $V_s=15V$  and  $25^\circ C$  ambient temperature unless otherwise specified.

Absolute Maximum Ratings	Test Conditions/ Note	Value	Unit		
Supply Voltage ( $V_s$ )		18	V		
Input Signal Voltage HIGH		5.5	V		
Input Signal Voltage LOW		0	V		
Output Peak Current ( $I_{out(PEAK)}$ )	Using $R_g < 10\Omega$	2	A		
Output Average Current ( $I_{out(AVG)}$ )	Per Channel	40	mA		
Output Power ( $P_{out}$ )	Per Channel	0.6	W		
Active Miller Clamp Current		1.7	A		
Maximum Working Insulation Voltage	$V_{peak}$	1414	V		
Input to Output Isolation	AC RMS	3000	V		
J1 5V Output Current ( $I_{OUT5V}$ )	Supply for external circuit	180	mA		
Operating Temperature	$I_{OUT5V} = 0$	-25 to +70	$^\circ C$		
Storage Temperature		-25 to +85	$^\circ C$		
Recommended Operating Conditions	Test Conditions/ Note	Minimum	Typical	Max	Unit
Supply Voltage ( $V_s$ )		13	15	17	V
Supply Current			100	300	mA
Operating temperature	$I_{OUT5V} = 0$	-10	-	70	$^\circ C$
Input Signal Voltage On/Off	3.3V control signals possible		5/0		V

## Ratings &amp; Characteristics (Continued)

\*All ratings are given at  $V_s=15V$  and  $25^\circ C$  ambient temperature unless otherwise specified.

Characteristics	Test Conditions/ Note	Minimum	Typical	Max	Unit
Logic High Input Threshold		2.0	-	-	V
Logic Low Input Threshold		-	-	0.8	V
Output Voltage HIGH (VoH)	15V supply, 20mA $I_{out(AVG)}$	11.49	12.39	12.41	V
Output Voltage LOW (VoL)		-	0.17	0.5	V
Output UVLO Threshold	ULVO +	10.5	11.6	12.5	V
	ULVO -	9.2	10.3	11.1	V
Output Clamp Threshold	Of Bi-directional TVS @ 1mA	16.7	-	18.5	V
Fault Output Voltage	Active LOW	-	-	0.8	V
Input Impedance	All inputs have 10 k $\Omega$ pull-down resistors	-	10	-	k $\Omega$
Internal Gate to Emitter Resistance		-	6.2	-	k $\Omega$
Duty Cycle Range		0	-	100	%
Configurable Dead-time	Using DT-ADJ	0.58	-	9.28	$\mu s$
Propagation Delay	$R_g=10\Omega$ , $C_g=10nF$ , $f=10kHz$ , Duty Cycle = 50%	100	180	250	ns
Pulse Width Distortion	$R_g=10\Omega$ , $C_g=10nF$ , $f=10kHz$ , Duty Cycle = 50%	-100	20	100	ns
Output Rise and Fall Time	$R_g=10\Omega$ , $C_g=10nF$ , $f=10kHz$ , Duty Cycle = 50%	-	50	-	ns
DESAT Threshold		6	6.5	7.5	V
DESAT Sense to 90%VO Delay ( $t_{DESAT(90\%)}$ )		-	0.15	0.5	$\mu s$
DESAT Sense to 10% VO Delay ( $t_{DESAT(10\%)}$ )		-	2	3	$\mu s$
DESAT Sense to Low Level FAULT Signal Delay ( $t_{DESAT(FAULT)}$ )		-	0.25	0.5	$\mu s$
DESAT Input Mute ( $t_{DESAT(MUTE)}$ )		5	-	-	$\mu s$
RESET to High Level FAULT Signal Delay ( $t_{RESET(FAULT)}$ )		0.3	1	2	$\mu s$
DESAT Blanking Time ( $t_{BLANK}$ )		-	2.7	-	$\mu s$
Common Mode Rejection (CMR)	At $V_{CM}=1500V$	50	60	-	kV/us
Weight	PX/TP Option	-	35	-	g
Dimensions	Width x Length x Depth	49.6 x 87.58 x 22.55			mm

### Block Diagram

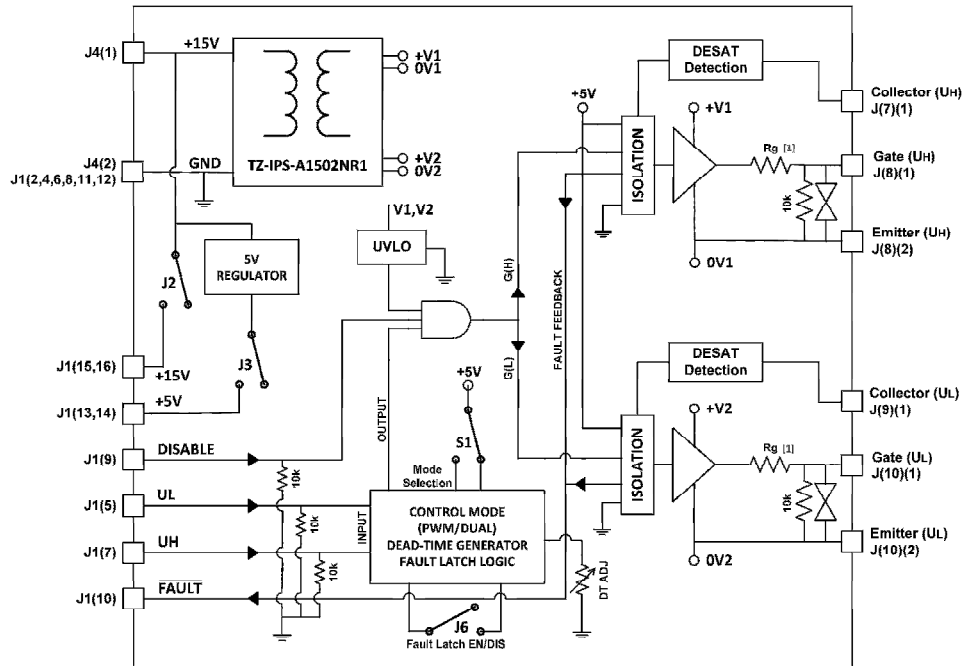
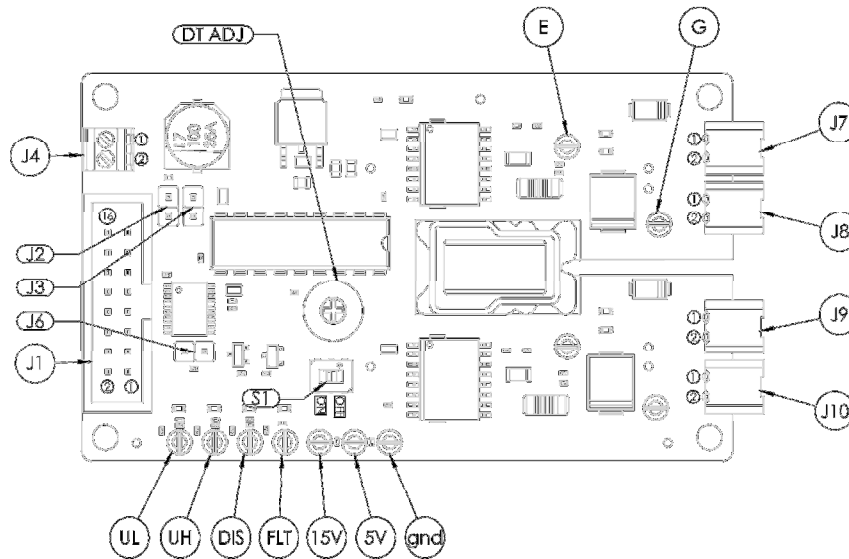

Figure 1: Block Diagram

### Notes:

- 1) The default gate resistor is 10Ω and user can control the gate turn on and off by changing Rg to lower value for faster switching, or higher value to minimize ringing. However, the minimum value to be used should be greater than or equal to IGBT/MOSFET datasheet recommended value for reliable operation.
- 2) In case of PWM mode, control signal will be generated from UH. User don't have to supply the UL.

### Pin Description



Name	Connector (Pin No.)	Description
UH	J1 (7)	Non-inverting logic input terminal for HIGH side gate.
UL	J1 (5)	Non-inverting logic input terminal for LOW side gate. (Dual mode only)
GND	J4(2) J1(2,4,6,8,11,12)	Ground
+15V	J4(1), J1 (15,16)	+15V supply voltage (Vs) for the module. It can be supplied either from J4 or J1 (if J2 is connected).
+5V	J1 (13,14)	+5V supply output from the module to power up the external circuit. Enabled by connecting J3.
DISABLE	J1 (9)	Input disable signal, active high will drive all outputs to LOW.
FLT	J1 (10)	Fault feedback output, active low. When a fault condition occurs, this pin will move into low state.
Collector	J(7,9)(1)	Output to IGBT/MOSFET collector terminal (must be connected).
NC	J(7,9)(2) J1(1,3)	This pin is not connected.
Gate	J(8,10)(1)	Output to IGBT/MOSFET gate terminal.
Emitter	J(8,10)(2)	Output to IGBT/MOSFET emitter terminal.
FAULT LATCH DISABLE	J6	By default this is not connected and the fault latch is enabled. This results in circuit operation to be disabled (until power reset) in case of fault condition. When connected, fault latch will be disabled, the circuit will resume operation after mute time (5us).
15V to J1	J2	If user wishes to supply +15V from J1 then J2 jumper must be connected.
5V to J1	J3	If user wishes to power up the external control circuitry from gate drive module then +5V can be supplied to J1 by connecting J3 jumper.
Dead-Time Adjust	DT-ADJ	Duration of Dead-time can be adjusted by DT-ADJ potentiometer.
PWM / Dual	S1	Operation mode can be selected by turning dead-time ON (PWM) or OFF (Dual).

## Application Information

### Typical Application Circuit

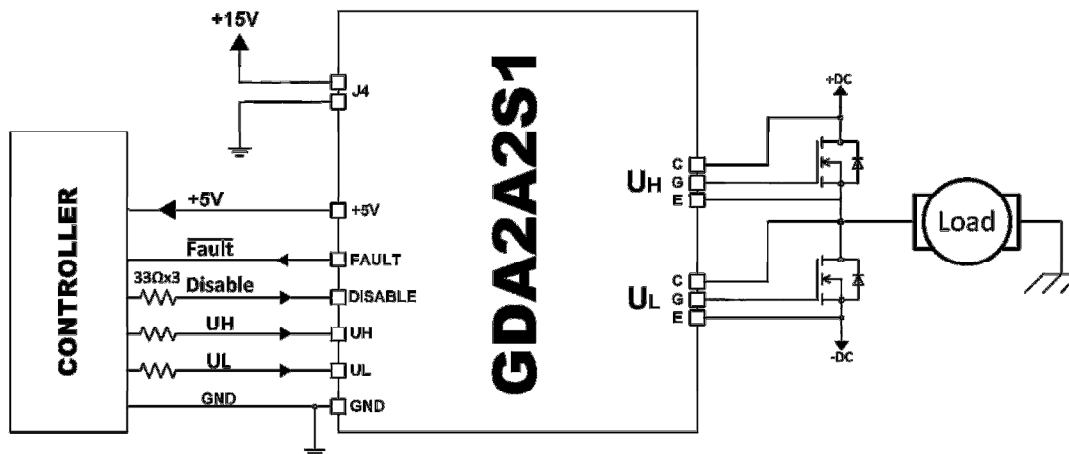

Figure 2: Typical application circuit

### Operational Requirements

For proper operation of the gate drive module, certain requirements need to be fulfilled. First, the module needs to be supplied with +15V voltage source through J4 or J1 connectors. Second, **all switches need to be connected including collector terminals**, failure to do so will latch the fault circuitry and module will become non-operational. Last, control signals need to be given to the module with recommended 33 Ohm transmission resistors to avoid ringing and noise. Disable signal must be in low state, while Fault signal can be monitored for feedback.

### Power Supply & Configuration (J2, J3& J4)

Supply voltage (+15V) is provided through J4 terminal block. It can also be supplied from J1 by connecting J2 jumper. Moreover, user can enable 5V output supply to external control circuitry by connecting J3 jumper.

### Output Connection (J7-J10)

Output connectors from J7 to J10 should be directly connected to power switches accordingly. These connectors come in multiple options (free hanging, terminal blocks or headers for plug in module). Please note that voltage difference between the collector and rest of output is high, and hence proper wiring and insulation must be used. Gate and emitter wires are recommended to be in twisted pairs in case of free hanging connectors and must be as short as possible.

### Fault Latch Disable (J6)

By default, fault latch logic is enabled to protect the switches from damage. Once a fault condition occurs, module will shut down and can only resume operation after power reset. However if the user wishes to control reset from the controller then J6 must be connected. At connected state, the fault latch will be disabled and module will resume operation after fault is cleared.



## Application Information (Continued)

Fault output pin (J1.10) indicates fault condition at any switch and is active LOW. Once fault is detected, the output will be muted for 5 $\mu$ s (minimum). Any input signal will be ignored during this mute period to allow driver to completely soft shut-down the IGBT.

### Operation Modes (S1)

User can select to use this gate driver as PWM or Dual input mode using one dip switch (S1). All gate driver modules are pre-configured in PWM mode by default. In PWM mode (S1 ON State), UL signal is generated by dead-time generation logic. The user has to connect only UH signal to Input. In Dual mode (S1 OFF State), both channels are independently controlled through respective signals, this is required for some topologies where shoot-through is needed such as Z-Source Inverter.

### Configurable Dead Time (DT ADJ) in PWM Mode

User can configure the internal dead time using DT ADJ potentiometer. The duration of dead time delay DT can be calculated as per equation 1.

$$DT \approx 0.39579 \times RDT$$

#### Equation 1.

Where: DT= dead time ( $\mu$ s), and RDT= on board dead time programming trimmer ( $k\Omega$ ), which varies from 1k to 21k $\Omega$ , changing dead time from 0.39579 $\mu$ s to 8.3 $\mu$ s. By default, the module is configured at 2.2 $\mu$ s dead time.

### Input & Output Indication LEDs, Test Points

LEDs are provided on input and output signals for instant user feedback. Input side LEDs are yellow colored. While output LEDs are independent for ON (Orange) state and OFF (Yellow) state so user can have feedback of high frequency PWM signals as well. Separate LEDs also indicate DISABLE (Orange), FAULT (RED) and Power state (Green).

The module contains input and output test points for easy debugging. This is very helpful feature for educational and research use. Test points are available on all inputs, Disable, Fault, Power (+15V, +5V, GND) and Gate, Emitter of all outputs.

### Mounting and Safety

Since output side carries dangerous high voltage, it is not safe to touch the circuit in operation. User must consider proper clearance of heat sink, metal enclosure, stray metallic objects near output side, and cover module and inverter with proper insulated casing. Care must be taken with mounting since mounting holes are close to outputs.

For more information, get our [Application Note](#) on how to design [Three Phase Inverter](#) to be used with our gate drive modules.

Visit: [www.taraztechnologies.com](http://www.taraztechnologies.com)

### Mechanical Drawing

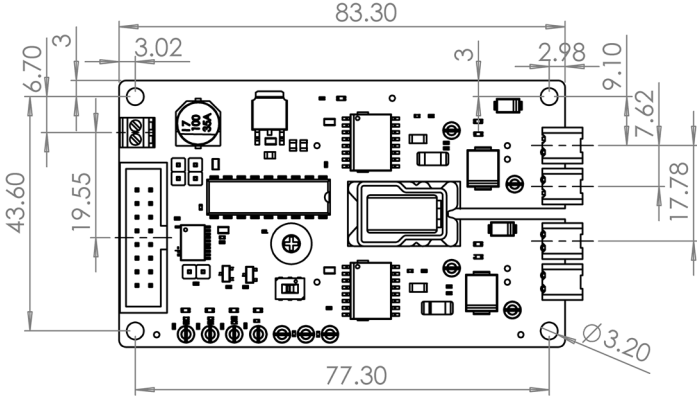

TOP VIEW

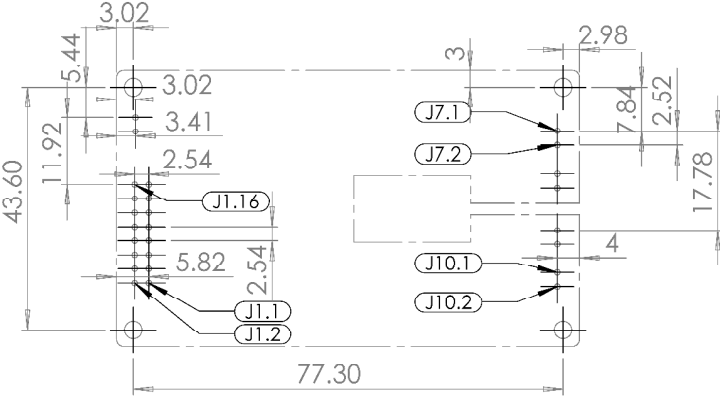

FOOTPRINT

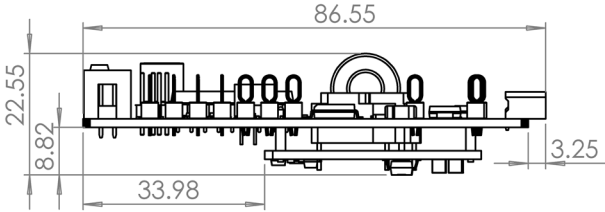

SIDE VIEW (PX OPTION)

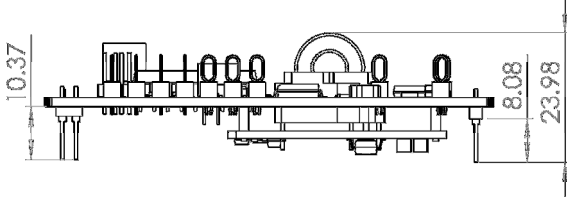

SIDE VIEW (PM OPTION)

### Notes:

\* All dimensions are in mm.

### Ordering Information

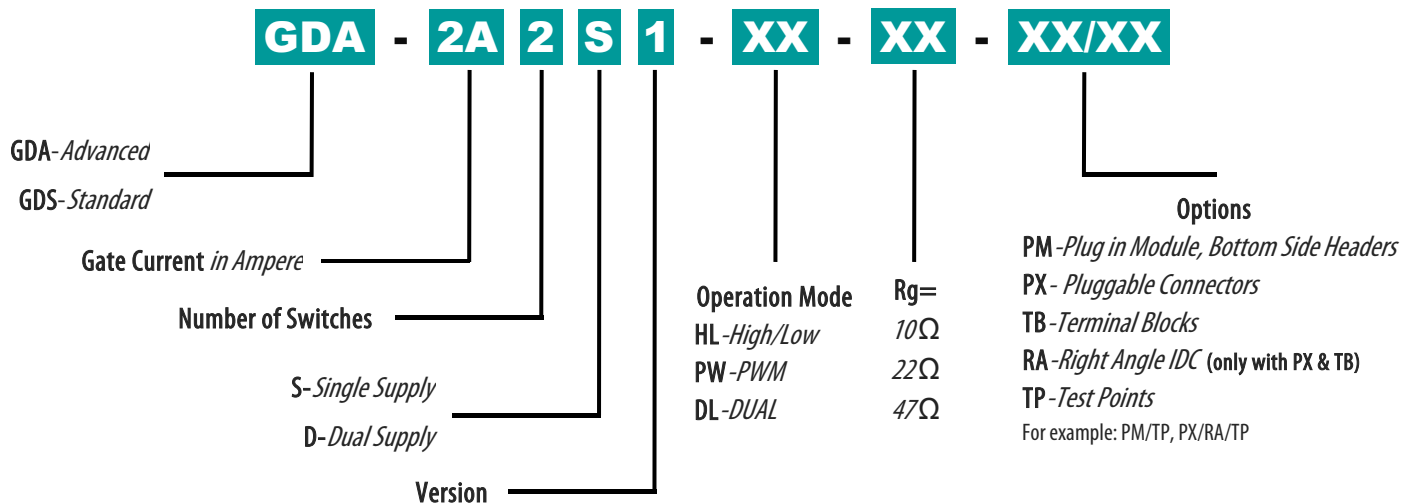

### Notes:

- 1) Either PM, PX or TB option can be selected.
- 2) Straight IDC is standard connector for J1 input connector and TB is standard for J4 connector. (Except in PM option)
- 3) PM (Plug in Module) option replace all connectors J1, J4 & J7-J10 with male headers soldered on the bottom side.
- 4) TP option can be selected with all configurations.
- 5) RA (Right Angle) option can be selected with PX & TB options only, which will replace standard straight IDC (J1) with right angle IDC.
- 6) The default gate resistor is 10Ω. However, the user can control gate turn on and off speed by changing Rg to a lower value for faster switching or higher value to minimize the ringing. The minimum value to be used should be greater than or equal to IGBT/MOSFET datasheet mentioned value for reliable operation.

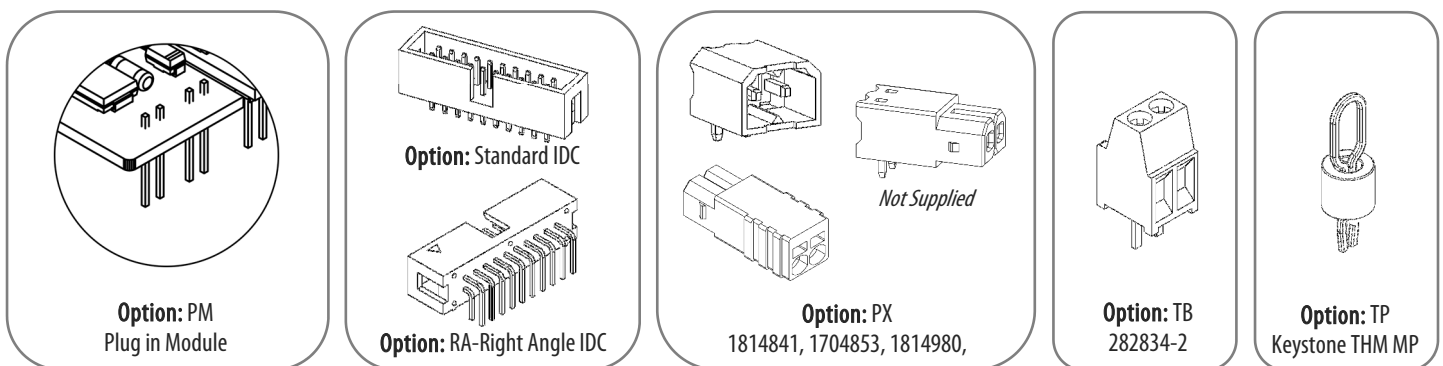

For Further information or purchasing, please go to our web site:

[www.taraztechnologies.com](http://www.taraztechnologies.com)

Address: Office# 201, Business Heights, 41 Spring North Commercial, Expressway, Bahria Town, Phase 7, Rawalpindi, Pakistan

Phone: +92 (51) 5400335

Fax: +92 (51) 5400155

E-Mail: [info@taraztechnologies.com](mailto:info@taraztechnologies.com)

Data subject to change. Copyright © 2015 Taraz Technologies. All rights reserved.

