



Applications

- 2 Switch Isolated IGBT/MOSFET Gate Drive
- Half Bridge Drives
- DC-DC Converters
- Switched Mode Power Supplies
- PFC Rectifiers

Compliance

- ROHS

Features

- Best Cost to Performance Ratio in the Market.
- Suitable for 1200V IGBTs and Power MOSFETs.
- 2A Peak Gate Drive Current.
- 3000 V_{RMS} Input to Output Isolation.
- Output UVLO Protection.
- Output Clamping Protection.
- Configurable Dead-Time.
- 20KV/us Minimum Common Mode Rejection (CMR).
- Very Low Propagation Delay of 75ns Maximum.
- Low Distortion at Extremely High Frequency Operation.
- PWM, High/Low Side and Dual Inputs Versions
- Input & Output Indication LEDs for Visual Feedback.
- Input & Output Test points for easy testing.
- Built-in 5V Regulator for Powering up External Control Circuitry.

Description

The GDS-2A2S1 is high performance fully isolated IGBT/MOSFET gate drive module for Single Leg 2 Switch, Half Bridge configuration. It is specially designed for fastest power electronics prototyping in research and educational environments. The drive use's Silicon Lab's Si823x high performance gate driver IC, and feature's dead time generation logic, overlap protection, input and output indication LEDs, test points and built in 5V regulator which could be used to power up external control circuitry.

But the most notable feature of this module is its extremely low propagation delay of less than 75ns. This is particularly important for very high switching frequency applications such as ZVS and ZCS topologies, it's also ideal for cascaded and parallel topologies to minimize differences between switches. Overall, this module will achieve fastest gate drive operation and lowest output signal distortion.

This product can be ordered with different input and output connectors, making it suitable as a plugin module, PCB mounted module or free hanging module.

Revision History Table

Version	Release Date	Changes
1.0	17/08/2015	First Version Released

WARNING AND DISCLAIMER !

ATTENTION PLEASE! THE INFORMATION HEREIN IS GIVEN TO DESCRIBE CERTAIN COMPONENTS AND SHALL NOT BE CONSIDERED AS A GUARANTEE OF CHARACTERISTICS. TERMS OF DELIVERY AND RIGHTS TO TECHNICAL CHANGE RESERVED. WE HEREBY DISCLAIM ANY AND ALL WARRANTIES, INCLUDING BUT NOT LIMITED TO WARRANTIES OF NON-INFRINGEMENT, REGARDING CIRCUITS, DESCRIPTIONS AND CHARTS STATED HEREIN. CUSTOMER IS SOLELY RESPONSIBLE OF PROPER AND LEGAL USE OF ALL PRODUCTS OFFERED BY TARAZ TECHNOLOGIES.

SAFETY NOTICE !

ATTENTION PLEASE! THIS DEVICE IS ESD SENSITIVE AND NEEDS TO BE HANDLED WITH CARE. HIGH VOLTAGE CONDITION MAY OCCUR DURING OPERATION OF THE DEVICE, AND HENCE USER IS SOLELY RESPONSIBLE OF EQUIPMENT AND PERSONNEL SAFETY. TARAZ TECHNOLOGIES SHALL NOT BE HOLD LIABLE FOR ANY DAMAGE TO PERSONNEL AND/OR PROPERTIES AS A RESULT OF USING THIS DEVICE. USER MUST TAKE ADEQUATE STEPS TO ENSURE ELECTRICAL AND MECHANICAL SAFETLY OF THE DEVICE IN USE.

Table of Contents

Features	1
Description	1
Compliance	1
Applications	1
Revision History Table.....	2
WARNING AND DISCLAIMER !	2
SAFETY NOTICE !	2
Table of Contents	3
Ratings & Characteristics	4
Ratings & Characteristics (Continued).....	5
Block Diagram	6
Pin Description	7
Application Information.....	8
Typical Application Circuit	8
Operation Requirements	8
Power Supply & Configuration (J2, J3& J4).....	8
Output Connection (J7, J8).....	8
PWM, High/Low and Dual Driver Versions	8
Application Information (Continued).....	9
Input & Output Indication LEDs, Test Points.....	9
Mounting and Safety.....	9
Mechanical Drawing	10
Ordering Information	11

Ratings & Characteristics

*All ratings are given at $V_s=15V$ and $25^\circ C$ ambient temperature unless otherwise specified.

Absolute Maximum Ratings	Test Conditions/ Note	Value	Unit
Supply Voltage (V_s)		18	V
Input Signal Voltage HIGH		5.5	V
Input Signal Voltage LOW		0	V
Output Peak Current ($I_{out(PEAK)}$)	Using $R_g < 10\Omega$	2	A
Output Average Current ($I_{out(AVG)}$)	Per Channel	33	mA
Output Power (P_{out})	Per Channel	0.5	W
Maximum Working Insulation Voltage	V_{peak}	891	V
Input to Output Isolation	AC RMS	3000	V
J1 5V Output Current (I_{OUT5V})	Supply for external circuit	180	mA
Operating Temperature	$I_{OUT5V} = 0$	-25 to +70	$^\circ C$
Storage Temperature		-25 to +85	$^\circ C$

Recommended Operating Conditions	Test Conditions/ Note	Minimum	Typical	Max	Unit
Supply Voltage (V_s)		13	15	17	V
Supply Current		-	100	300	mA
Operating temperature	$I_{OUT5V} = 0$	-10	-	70	$^\circ C$
Input Signal Voltage On/Off	3.3V control signals possible	-	5/0	-	V

Ratings & Characteristics (Continued)

*All ratings are given at $V_S=15V$ and $25^\circ C$ ambient temperature unless otherwise specified.

Characteristics	Test Conditions/ Note	Minimum	Typical	Max	Unit
Logic High Input Threshold		2.0	-	-	V
Logic Low Input Threshold		-	-	0.8	V
Output Voltage HIGH (VOH)	$V_S = 15V, 1mA I_{out(AVG)}$	-	14.5	-	V
Output Voltage LOW (VOL)	$V_S = 15V$	-	-	0.04	V
Output UVLO Threshold	UVLO +	7.5	8.6	9.4	V
	UVLO -	7.2	8.1	8.7	V
Output Clamp Threshold	Of Bi-directional TVS @ 1mA	16.7	-	18.5	V
Input Impedance	All inputs have 10 k Ω pull-down resistors	-	10	-	k Ω
Minimum Pulse Width		-	10	-	ns
Duty Cycle Range		0	-	100	%
Configurable Dead-time	No RDT	0.4	-	-	ns
	RDT=220k Ω	-	-	2200	ns
Dead-Time Resistor (RDT)		0	-	220	k Ω
Propagation Delay		-	-	75	ns
Pulse Width Distortion		-	-	10	ns
Output Rise and Fall Time		-	-	40	ns
Common Mode Rejection (CMR)	At $V_{CM}=1500V$	20	45	-	kV/us
Weight	PX/TP Option	-	32	-	g
Dimensions (Bare)	Width x Length x Depth		49.6 x 83.3 x 29.32		mm

Block Diagram

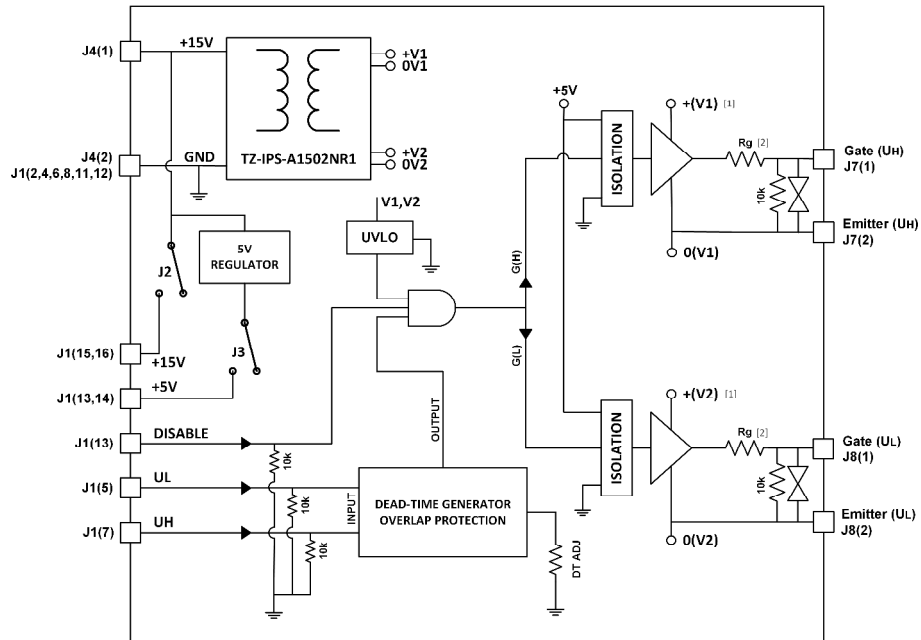
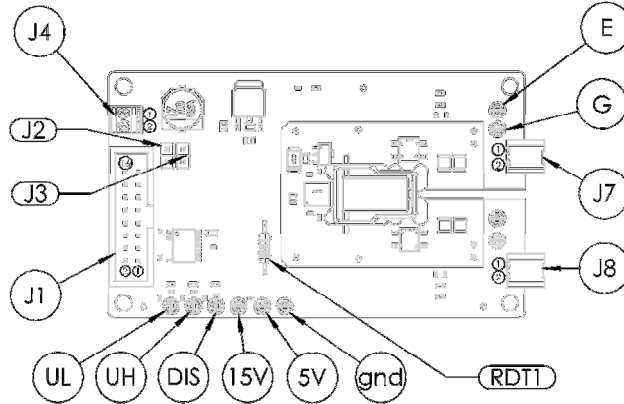

Figure 1: Block Diagram

Notes:

- 1) Both drivers are powered by two isolated power sources.
- 2) The default gate resistor is 10Ω and user can control the gate turn on and off by changing Rg to lower value for faster switching, or higher value to minimize ringing. However, the minimum value to be used should be greater than or equal to IGBT/MOSFET datasheet recommended value for reliable operation.
- 3) In PWM Driver, control signal will be generated from UH. User don't have to supply the UL signal.

Pin Description



Name	Connector (Pin No.)	Description
UH	J1 (7)	Non-inverting logic input terminal for HIGH side gate.
UL	J1 (5)	Non-inverting logic input terminal for LOW side gate. (High Low & Dual input versions)
GND	J4(2), J1 (2,4,6,8,11,12)	Ground
+15V	J4(1), J1 (15,16)	+15V supply voltage (V_s) for the module. It can be supplied either from J4 or J1 (if J2 is connected).
+5V	J1 (13,14)	+5V supply output from the module to power up the external circuit. Enabled by connecting J3.
DISABLE	J1 (9)	Input disable signal, active high will drive all outputs to LOW.
NC	J1 (10)	This pin is not connected.
Gate	J(7,8)(1)	Output to IGBT/MOSFET gate terminal.
Emitter	J(7,8)(2)	Output to IGBT/MOSFET emitter terminal.
15V to J1	J2	If user wish to supply +15V from J1 then J2 jumper must be connected.
5V to J1	J3	If user wish to power up the external control circuitry from gate drive module then +5V can be supplied to J1 by connecting J3 jumper.
Dead-Time Adjust	RDT(1)	Duration of Dead-time can be configured by RDT resistor.

Application Information

Typical Application Circuit

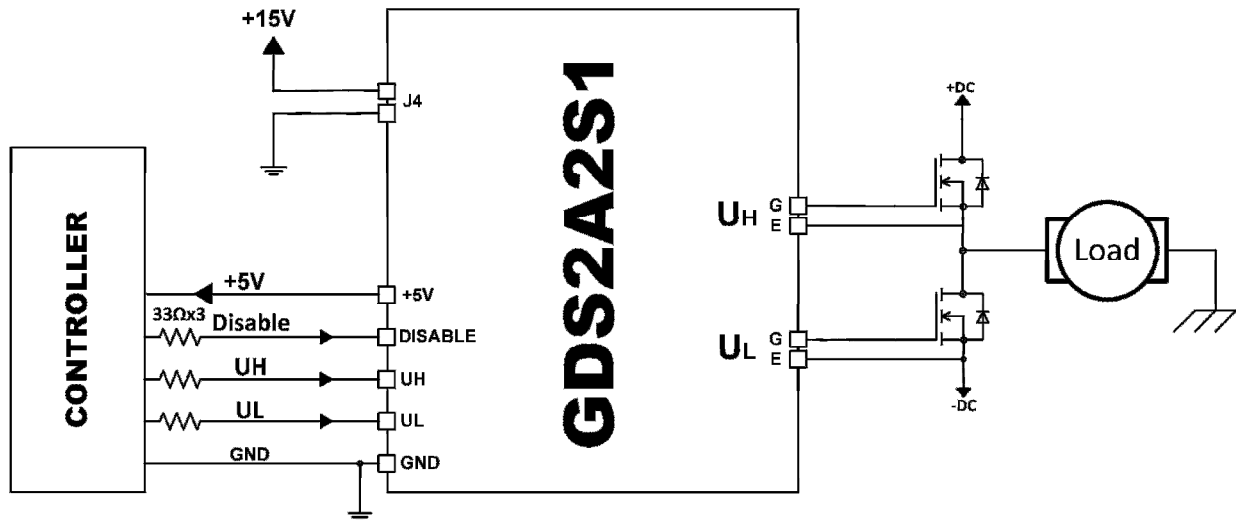

Figure 2: Typical application circuit

Operation Requirements

For proper operation of the gate drive module, certain requirements need to be fulfilled. First, the module needs to be supplied with +15V voltage source through J4 or J1 connectors. Second, control signals need to be given to the module with recommended 33 Ohm transmission resistors to avoid ringing and noise. Disable signal must be in low state, otherwise all outputs will be unconditionally driven to low level.

Power Supply & Configuration (J2, J3 & J4)

Supply voltage (+15V) is provided through J4 terminal block. It can also be supplied from J1 by connecting J2 jumper. Moreover, user can enable 5V output supply to external control circuitry by connecting J3 jumper.

Output Connection (J7, J8)

This module is designed to drive half bridge inverter in dual half bridge configuration, however, both switches can be independently operated in dual version (because both gate drivers have its own isolated supply). Output connectors from J7, J8 should be directly connected to power switches accordingly.

These connectors come in multiple options (free hanging, terminal blocks or headers for plug in module). Gate and emitter wires are recommended to be in twisted pairs in case of free hanging connectors and must be as short as possible.

PWM, High/Low and Dual Driver Versions

User can select any version of the gate driver as per requirement. The available options include PWM driver, High/Low driver and Dual Driver. In PWM driver version (GDS-2A2S1-**PW**-XX-XX/XX), user has to provide high side signals (UH, VH, WH) only. Low side signals are internally generated through dead-time generation logic. The duration of dead-time can be configured by RDT resistors (3 resistors, each per leg) as per requirements. Following equation is used to calculate RDT value according to desired dead-time:

$$DT \approx 10 \times RDT$$

Equation 1.

Where: DT=dead time (ns), and RDT= Dead time programming resistor (kΩ). If no resistor is used, then default value of dead-time is 400 ps. Note that 220kΩ is the largest value of RDT that can be used.

Application Information (Continued)

In High/Low Driver version (GDS-2A2S1-**HL**-XX-XX/XX), both switches of the leg are controlled through their respective signals. This module comes with built-in overlap protection to prevent same phase outputs (e.g., UH & UL) from being high at the same time. The dead-time is user adjusted using RDT configuration resistors using Equation 1.

In Dual Driver version (GDS-2A2S1-**DL**-XX-XX/XX), all channels are independently controlled through respective signals, this is required for some topologies where shoot-through is needed such as Z-Source Inverter. Following table illustrate discussed versions.

PWM Version				
Inputs			Outputs	
UH	UL	Disable	UOH	UOL
L	X	L	L	H
H	X	L	H	L
X	X	H	L	L
High/Low Version				
Inputs			Outputs	
UH	UL	Disable	UOH	UOL
L	L	L	L	L
L	H	L	L	H
H	L	L	H	L
H	H	L	L	L
X	X	H	L	L
Dual Version				
Inputs			Outputs	
UH	UL	Disable	UOH	UOL
L	L	L	L	L
L	H	L	L	H
H	L	L	H	L
H	H	L	H	H
X	X	H	L	L

Input & Output Indication LEDs, Test Points

LEDs are provided on input and output signals for instant user feedback. Input side LEDs are yellow colored. While output LEDs are independent for ON (Orange) state and OFF (Yellow) state so user can have feedback of high frequency PWM signals as well. Separate LEDs also indicate DISABLE (Orange) and Power state (Green).

The module can also be supplied with input and output test points for easy debugging. This is very helpful feature for educational and research use. Test points are available on all inputs, Disable, Power (+15V, +5V, GND) and Gate, Emitter of all outputs.

Mounting and Safety

Since output side may carry dangerous high voltage, it is not safe to touch the circuit in operation. User must consider proper clearance of heat sink, metal enclosure, stray metallic objects near output side, and cover module and inverter with proper insulated casing. Care must be taken with mounting since mounting holes are close to outputs.

For more information, get our [Application Note](#) on how to design [Three Phase Inverter](#) to be used with our gate drive modules.

Visit: www.taraztechnologies.com

Mechanical Drawing

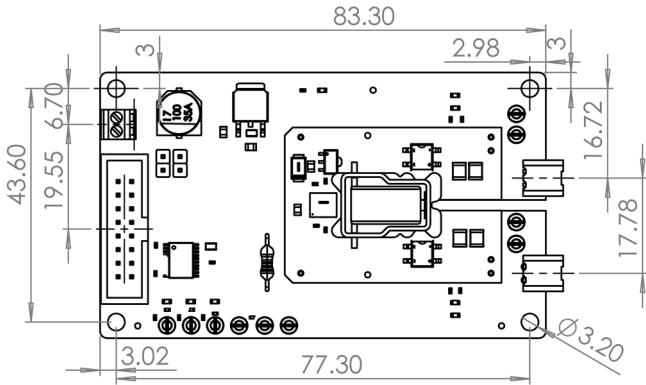

TOP VIEW

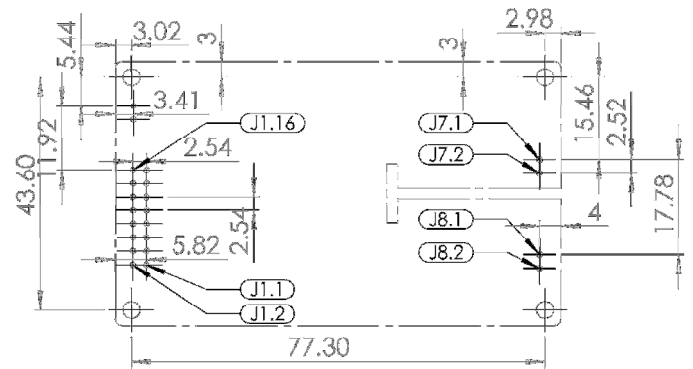

FOOTPRINT

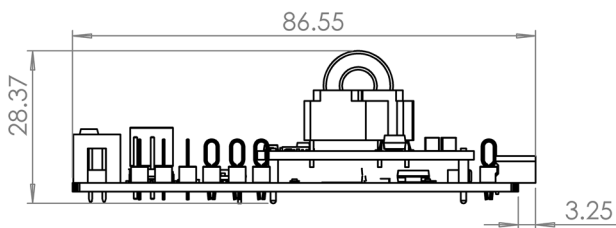

SIDE VIEW (PX OPTION)

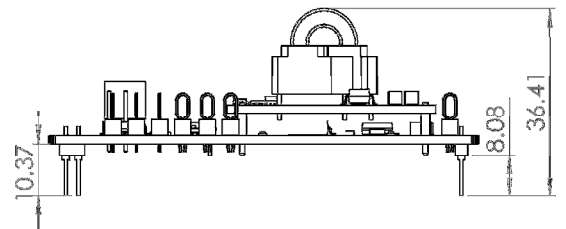

SIDE VIEW (PM OPTION)

Notes:

* All dimensions are in mm.

Ordering Information

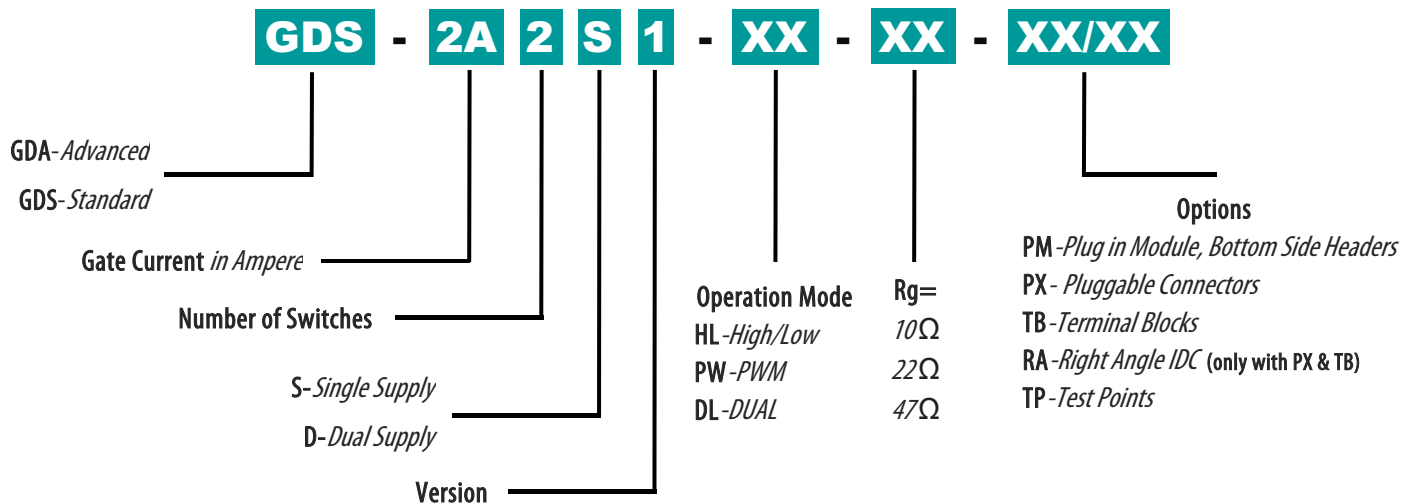

Notes:

- 1) Either PM, PX or TB option can be selected.
- 2) Straight IDC is standard connector for J1 input connector and TB is standard for J4 connector. (Except in PM option)
- 3) PM (Plug in Module) option replace all connectors J1, J4 & J7, J8 with male headers soldered on the bottom side.
- 4) TP option can be selected with all configurations.
- 5) RA (Right Angle) option can be selected with PX & TB options only, which will replace standard straight IDC (J1) with right angle IDC.
- 6) The default gate resistor is 10Ω. However, user can control gate turn on and off speed by changing Rg to a lower value for faster switching or higher value to minimize ringing effect. The minimum value to be used should be greater than or equal to IGBT/MOSFET datasheet recommended value for reliable operation.

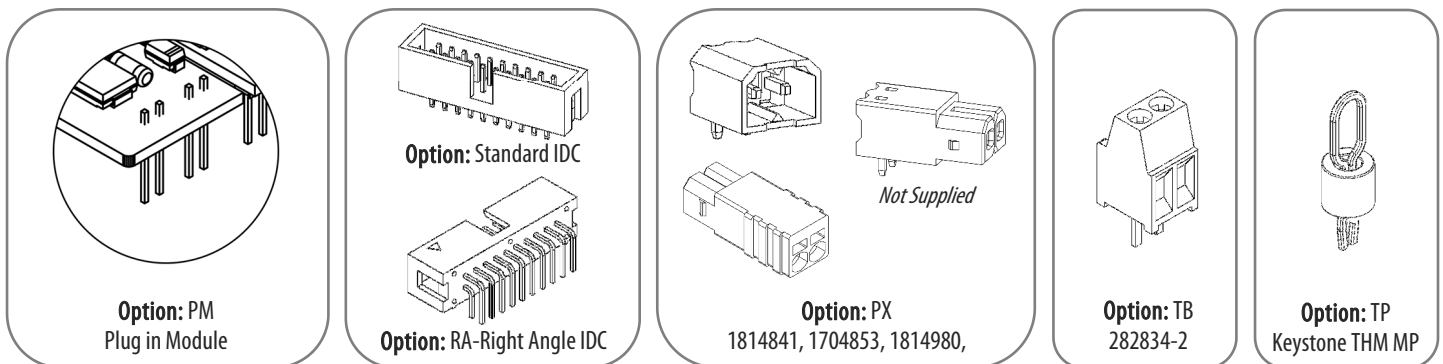

For Further information or purchasing, please go to our web site:

www.taraztechnologies.com

Address: Office# 201, Business Heights, Spring North Commercial, Expressway, Bahria Town, Phase 7, Rawalpindi, Pakistan

Phone: +92 (51) 5400335

Fax: +92 (51) 5400155

E-Mail: info@taraztechnologies.com

Data subject to change. Copyright © 2015 Taraz Technologies. All rights reserved.

